

ORIGINAL MINI ACCESSORIES. INSTALLATION INSTRUCTIONS.



Mission Control retrofit

MINI Clubman (R55)

MINI Clubman S (R55)

MINI One (R56)

MINI Cooper (R56)

MINI Cooper S (R56)

MINI Cooper Convertible (R57)

MINI Cooper S Convertible (R57)

Retrofit kit No. 65 41 2 154 719 Mission Control retrofit kit

Installation time

The installation time is **approx. 0.1 hours**. This may vary depending on the condition of the car and the equipment in it.

Important information

These installation instructions are primarily designed for use within the MINI dealership organisation and by authorised BMW service companies.

In any event the target group for these installation instructions is specialist personnel trained on MINI cars with the appropriate specialist knowledge.

All work must be completed using the latest MINI repair manuals, circuit diagrams, servicing manuals and work instructions, in a rational order, using the prescribed tools (special tools) and observing current health and safety regulations.

If you experience installation or function problems, limit troubleshooting to approx. 0.5 hours for mechanical or 1.0 hour for electrical work.

In order to reduce costs and avoid any additional expense, send a query immediately to the Technical Parts Support via the Aftersales Assistance Portal (ASAP).

Specify the following information:

- Chassis number
- Part number of the retrofit kit
- A precise description of the problem
- Work steps already carried out

Do not archive the hard copy of these installation instructions since daily updates are made by ASAP!

Installation information

All pictures show LHD cars; proceed accordingly on RHD cars.

Ensure that the cables and/or lines are not kinked or damaged as you install them in the car. The costs thereby incurred will not be reimbursed by BMW AG.

Special tools required

None

Table of contents

Section	Page
1. Parts list	3
2. Fit storage box containing Mission Control unit	4
3. Circuit diagram	5

1. Parts list

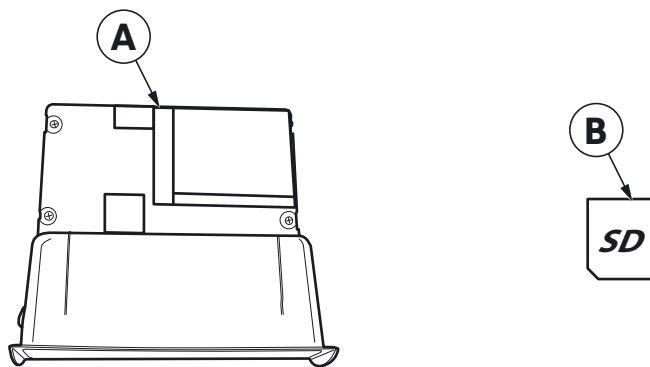

R56 0452 Z

Legend

- A** Storage box with Mission Control unit
- B** SD card (already inserted in control unit)

2. Fit storage box with Mission Control unit

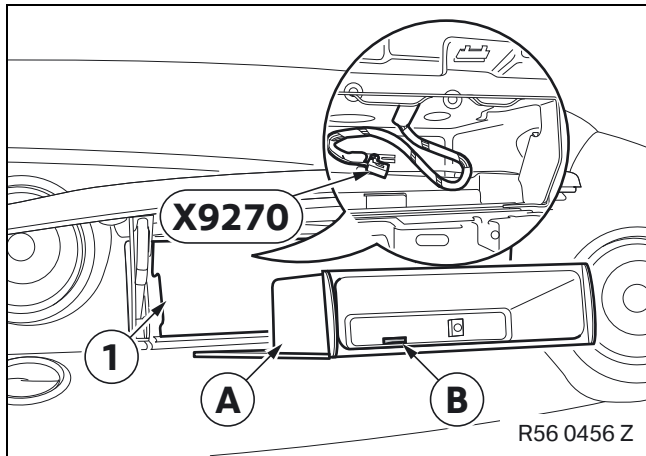

Release tied-back plug **X9270** in the storage compartment recess (1) and connect to Mission Control unit **A**.

Insert storage box with Mission Control unit **A** into storage compartment recess (1).

Function test:

- LED on: System switched on
- LED flashing: SD card **B** not correctly inserted or data cannot be read
- LED off: System switched off

3. Circuit diagram

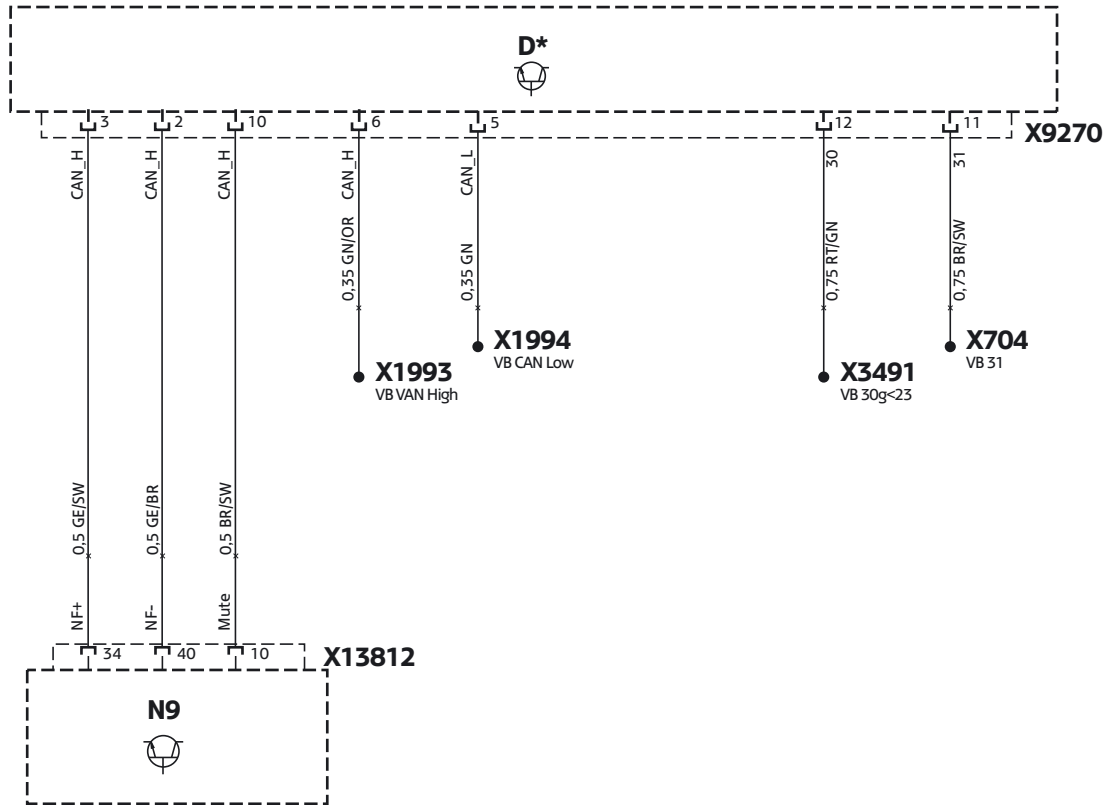

R56 0455 Z

Legend

- X704** Terminal 31 connector
- X1993** CAN High connector
- X1994** CAN Low connector
- X3491** Terminal 30g connector
- X9207** 12-pin SW socket casing, to Mission Control unit **D***
- X13812** 40-pin socket casing, SW, to radio, **N9**

All the designations marked with an asterisk (*) apply only to these installation instructions or this circuit diagram.

Cable colours

BR	Brown	OR	Orange
GE	Yellow	RT	Red
GN	Green	SW	Black